

282 Series

Brass 2-way Full Port Ball Valve

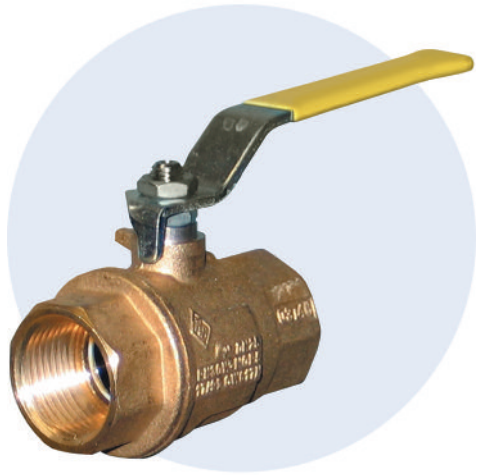

The 282 series manual ball valves are full port, brass, manual ball valves. They are available with NPT Female, NPT Male x Female, and Solder end connections. Five different manual handle configurations are offered.

FEATURES

- Full port ball drilling for unrestricted flow.
- Investment cast 2-piece brass body.
- Blow-out proof stem.
- Compact assembly.
- Locking device.
- Adjustable stem packing.
- 100% factory tested.

HANDLE CONFIGURATIONS

- Standard lever.
- Locking lever.
- Lever with extension.
- Oval (up to 2").
- Tee (up to 1").

PRESSURE RANGE

29 inHg vacuum to 600 PSI (WOG)
29 inHg vacuum to 150 PSI (WSP)

TEMPERATURE RANGE

Up to 366°F

SPECIFICATIONS

End Connections:

NPT (female), 1/4" to 4".
NPT (male x female), 1/4" to 1".
Solder, 1/2" to 1/4".

HANDLE REFERENCE



Standard

Locking

Extension

Oval

Tee

MATERIALS OF CONSTRUCTION

Part	Qty.	Description	Standard Material
1	1	Body	Brass CW 617N UNI EN 12165
2	1	End Cap	Brass CW 617N UNI EN 12165
3	1	Ball	Brass CW 617N UNI EN 12165
4	2	Seat	PTFE
5	2	Thrust Washer	PTFE
6	1	O-Ring	NBR
7	1	Packing Gland	Brass CW 614N UNI EN 12164
8	2	Nut	Steel 6S
9	1	Stem	Brass CW 614N UNI EN 12164
10	1	Handle	Fe P11 UNI EN 10111

CV FACTORS

Size	CV (N)	CV (M)	CV (S)
1/4"	6.29	6.29	-
3/8"	6.99	6.99	-
1/2"	19.00	19.00	.98
3/4"	34.40	34.40	1.22
1"	50.10	50.00	1.50
1-1/4"	103.70	-	1.90
1-1/2"	268.40	-	2.12
2"	309.20	-	2.64
2-1/2"	629.00	-	3.54
3"	1018.00	-	4.13
4"	1622.00	-	5.12

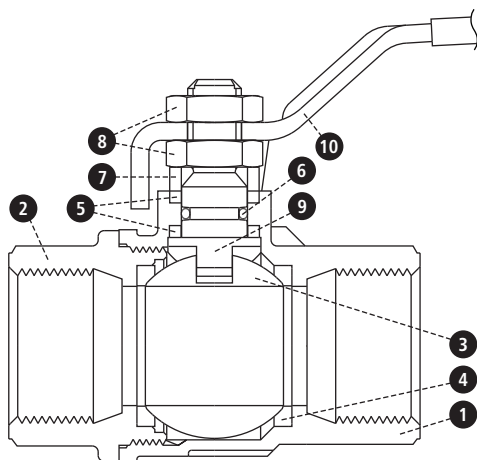

282N Series

Brass 2-way Full Port Ball Valve

(Threaded end connection, female x female, 2 piece body)

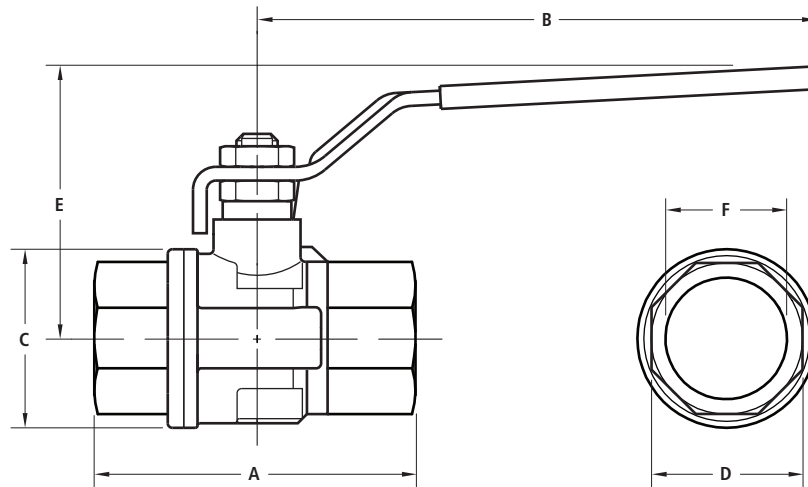

DIMENSIONS, WEIGHTS & ADDITIONAL SPECIFICATIONS

Size	A	B	C	D	E	F	Wt. (lbs.)	Model No.
1/4"	2.02	3.78	.90	.78	1.65	.250	.33	A282N \odot
3/8"	2.02	3.78	.90	.78	1.65	.375	.30	B282N \odot
1/2"	2.44	3.78	1.25	.98	1.81	.500	.48	C282N \odot
3/4"	2.71	4.76	1.53	1.22	2.28	.750	.79	D282N \odot
1"	3.07	4.76	1.92	1.49	2.44	1.00	1.22	E282N \odot
1-1/4"	3.42	5.94	2.32	1.88	3.00	1.25	2.14	F282N \odot
1-1/2"	3.89	5.95	2.87	2.12	3.23	1.50	3.20	G282N \odot
2"	4.33	6.30	3.38	2.63	3.74	2.00	4.08	H282N \odot
2-1/2"	5.59	8.11	4.37	3.54	4.84	2.50	8.28	I282N \odot
3"	6.45	8.11	5.35	4.13	5.23	3.00	13.00	J282N \odot
4"	7.60	10.27	6.35	5.12	6.49	4.00	22.07	K282N \odot

\odot Handle Configuration: A = Standard lever; L = Locking lever; E = Lever with extension; O = Oval; T = Tee.

282N VALVE FEATURES

- Full port ball drilling for unrestricted flow.
- Investment cast 2-piece brass body.
- Blow-out proof stem.
- Compact assembly.
- Locking device.
- Adjustable stem packing.
- 100% factory tested.
- Temperature range: Up to 366°F.
- Pressure range: 29 inHg vacuum to 600 PSI (WOG)
29 inHg vacuum to 150 PSI (WSP).
- CSA-C/US and UL approved.
- FM and UL EPH NSF 61 approved up to 2" .

282M Series

Brass 2-way Full Port Ball Valve

(Threaded end connection, male x female, 2 piece body)

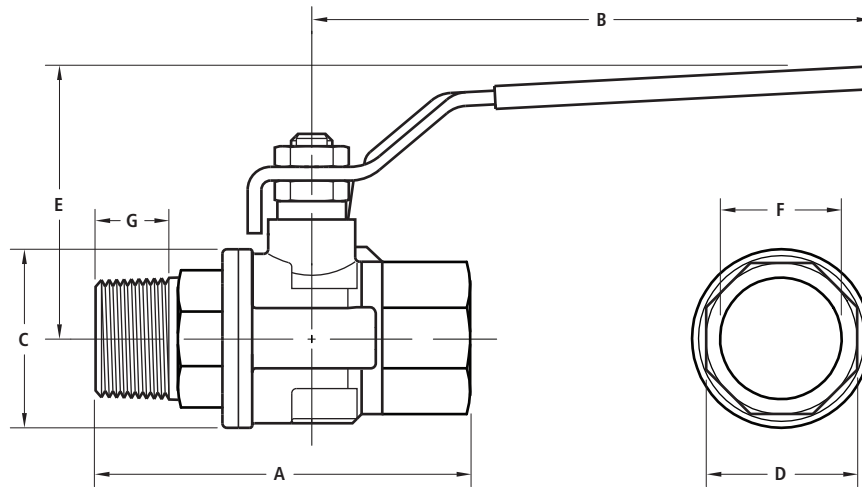

DIMENSIONS, WEIGHTS & ADDITIONAL SPECIFICATIONS

Size	A	B	C	D	E	F	G	Wt. (lbs.)	Model No.
1/4"	2.30	3.78	.90	.78	1.65	.250	.40	.31	A282M [⊙]
3/8"	2.32	3.78	.90	.78	1.65	.375	.41	.31	B282M [⊙]
1/2"	2.81	3.78	1.25	.98	1.81	.500	.53	.51	C282M [⊙]
3/4"	3.13	4.76	1.53	1.22	2.28	.750	.55	.79	D282M [⊙]
1"	3.58	4.76	1.92	1.49	2.44	1.00	.68	1.26	E282M [⊙]

[⊙] Handle Configuration: A = Standard lever; L = Locking lever; E = Lever with extension; O = Oval; T = Tee.

282M VALVE FEATURES

- Full port ball drilling for unrestricted flow.
- Investment cast 2-piece brass body.
- Blow-out proof stem.
- Compact assembly.
- Locking device.
- Adjustable stem packing.
- 100% factory tested.
- Temperature range: Up to 366°F.
- Pressure range: 29 inHg vacuum to 600 PSI (WOG)
29 inHg vacuum to 150 PSI (WSP).
- CSA-C/US, FM and UL approved.

282S Series

Brass 2-way Full Port Ball Valve (Solder end connection, 2 piece body)

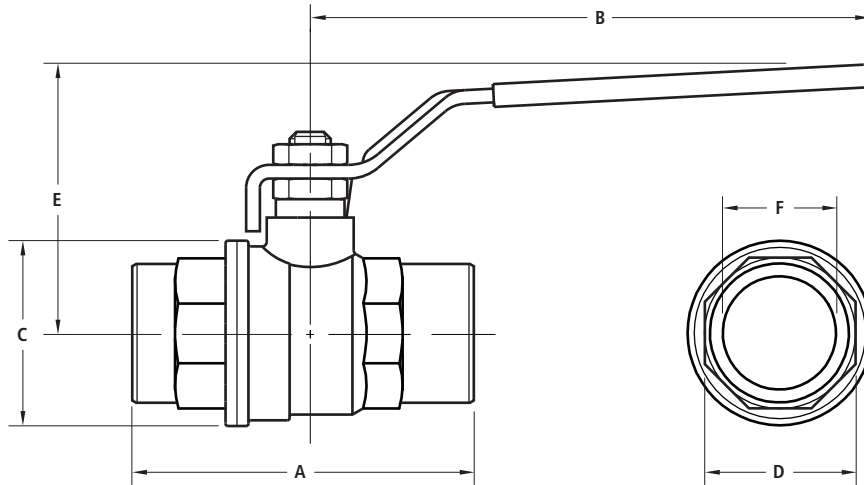

DIMENSIONS, WEIGHTS & ADDITIONAL SPECIFICATIONS

Size	A	B	C	D	E	F	Wt. (lbs.)	Model No.
1/2"	2.58	3.78	1.30	.98	1.81	.63	.50	C282S⊙
3/4"	3.00	4.76	1.53	1.22	2.28	.88	.77	D282S⊙
1"	3.56	4.76	1.93	1.50	2.44	1.13	1.19	E282S⊙
1-1/4"	4.09	5.94	2.32	1.90	3.00	1.38	2.20	F282S⊙
1-1/2"	4.56	5.95	2.87	2.12	3.23	1.63	3.24	G282S⊙
2"	5.45	6.30	3.38	2.64	3.74	2.13	4.21	H282S⊙
2-1/2"	6.90	8.11	4.37	3.54	4.84	2.63	9.44	I282S⊙
3"	8.05	8.11	5.35	4.13	5.23	3.13	14.52	J282S⊙
4"	10.25	10.27	6.53	5.12	6.49	4.13	24.83	K282S⊙

⊙ Handle Configuration: A = Standard lever; L = Locking lever; E = Lever with extension; O = Oval; T = Tee.

282S VALVE FEATURES

- Full port ball drilling for unrestricted flow.
- Investment cast 2-piece brass body.
- Blow-out proof stem.
- Compact assembly.
- Locking device.
- Adjustable stem packing.
- 100% factory tested.
- Temperature range: Up to 366°F.
- Pressure range: 29 inHg vacuum to 600 PSI (WOG)
29 inHg vacuum to 150 PSI (WSP).
- UL EPH NSF 61 approved up to 2".