

33D Series

Stainless Steel 3-way Full Port Ball Valve



The 33D is a full port, 3-way, 316 stainless steel, NPT threaded end multi port ball valve. It can be equipped with a manual handle or with direct mount pneumatic or electric actuators. The direct mount actuators eliminate the valve-actuator mounting kit, which adds unnecessary height and expense.

A full range of accessory items are available including limit switches, and solenoid valves.

FEATURES

- Full port for unrestricted flow.
- Blow-out proof stem.
- Integrated mounting pad for actuators.
- Compact assembly.
- Complete line of accessories.

ACTUATOR CONFIGURATIONS

- Electric.
- Pneumatic (spring return).
- Pneumatic (double acting).
- Manual handle.

PRESSURE RANGE

29 inHg vacuum to 800 PSI

TEMPERATURE RANGE

-20°F to 400°F

TYPICAL APPLICATIONS

- Air drying equipment, sterilizers and autoclaves.
- Pollution control equipment.
- Process control applications.
- Laundry equipment.
- Textile dyeing and drying.
- Bottling and dispensing.
- Ink and paint dispensing.

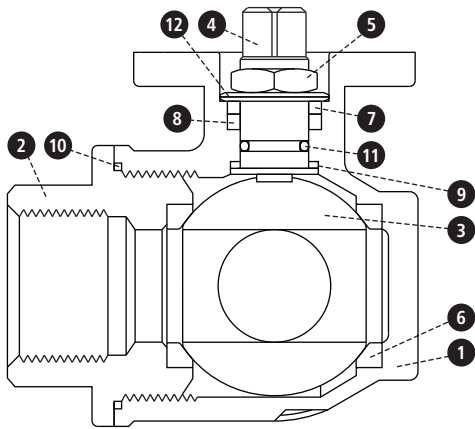

PORT ARRANGEMENTS

L Port		T Port			
Flow Plan A	Flow Plan D	Flow Plan E	Flow Plan F	Flow Plan G	
Pos1 Pos2	Pos1 Pos2	Pos1 Pos2	Pos1 Pos2	Pos1 Pos2	

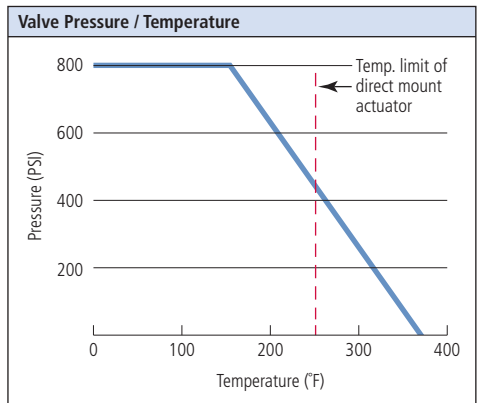

MATERIALS OF CONSTRUCTION

Part	Qty.	Description	Standard Material
1	1	Body	ASTM A351 Gr. CF8M
2	3	End Cap	ASTM A351 Gr. CF8M
3	1	Ball	316 Stainless Steel
4	1	Stem	316 Stainless Steel
5	1	Stem Nut	304 Stainless Steel
6	4	Seat	PTFE
7	1	Gland	304 Stainless Steel
8	1	Stem Packing	PTFE
9	1	Thrust Washer	RPTFE
10	4	Body O-Ring	PTFE
11	1	Stem O-Ring	Viton®
12	2	Bellville Washer	301 Stainless Steel

CV FACTORS

Size	CV
1/4"	3.2
3/8"	3.5
1/2"	4.5
3/4"	10
1"	16
1-1/4"	31
1-1/2"	49
2"	82

33DXM Series

Stainless steel 3-way full port ball valve with manual handle
(Threaded end connection)

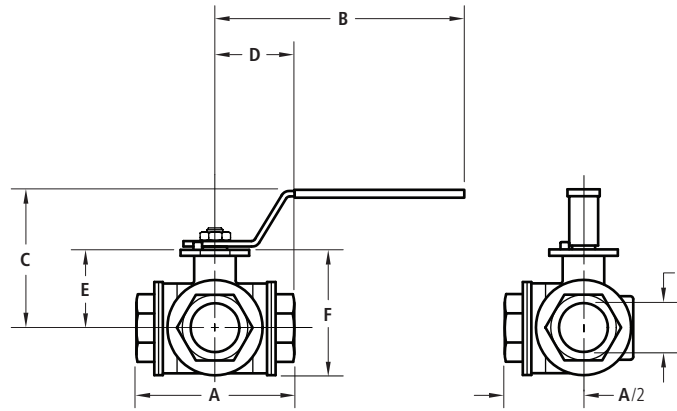

DIMENSIONS, WEIGHTS & SPECIFICATIONS

Size	A	B	C	D	E	F	I	Wt. (lbs.)	Model No.
1/4"	2.84	5.12	2.44	1.42	1.54	2.18	.250	2.0	A33D⊙XM
3/8"	2.84	5.12	2.44	1.42	1.54	2.18	.375	2.0	B33D⊙XM
1/2"	3.27	5.12	2.52	1.63	1.62	2.50	.500	2.0	C33D⊙XM
3/4"	3.90	6.50	3.23	1.95	1.93	2.95	.750	3.0	D33D⊙XM
1"	4.41	6.50	3.50	2.20	2.17	3.45	1.000	5.0	E33D⊙XM
1-1/4"	4.93	8.08	3.86	2.46	2.48	3.97	1.250	6.0	F33D⊙XM
1-1/2"	5.87	8.08	4.25	2.93	2.92	4.66	1.500	11.0	G33D⊙XM
2"	6.85	12.81	5.52	3.42	3.66	5.88	2.000	20.0	H33D⊙XM

⊙ Flow Plan: A, D, E, F, G (see Port Arrangements diagram).

33D VALVE FEATURES

- Full port stainless steel body, ball and blow out proof stem.
- 3-way valve with investment cast body.
- NPT threaded end connection.
- RPTFE seats and seals.
- Mounting pad for direct mount.
- Temperature range: -20°F to 400°F.
- Pressure range: 29 inHg vacuum to 800 PSI.

33DXEDA Series

Stainless steel 3-way full port ball valve with double acting pneumatic actuator
(Threaded end connection, actuators are sized for 400 PSI pressure differential)

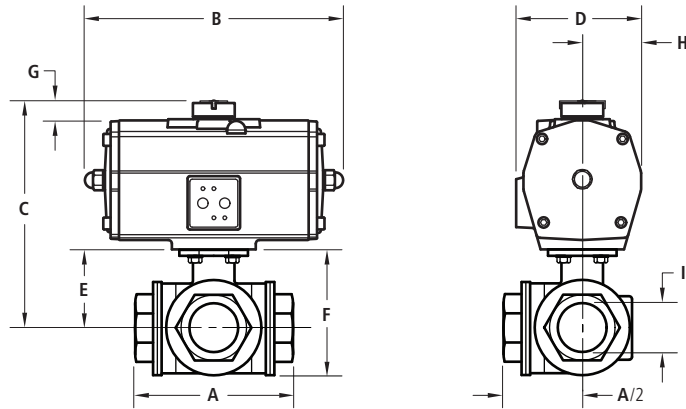

DIMENSIONS, WEIGHTS & SPECIFICATIONS

Size	A	B	C	D	E	F	G	H	I	Actuator	Wt. (lbs.)	Model No.
80 PSI Minimum Actuator Air Supply = 8D												
1/4"	2.84	6.26	5.48	3.26	1.54	2.18	.79	1.46	.250	ED25	4.9	A33D⊙XE8D
3/8"	2.84	6.26	5.48	3.26	1.54	2.18	.79	1.46	.375	ED25	4.9	B33D⊙XE8D
1/2"	3.27	6.26	5.56	3.26	1.62	2.50	.79	1.46	.500	ED25	4.9	C33D⊙XE8D
3/4"	3.90	6.26	5.87	3.26	1.93	2.95	.79	1.46	.750	ED25	5.9	D33D⊙XE8D
1"	4.41	7.09	6.62	3.78	2.17	3.45	.79	1.70	1.000	ED40	9.0	E33D⊙XE8D
1-1/4"	4.93	7.83	7.40	4.19	2.48	3.97	.79	1.93	1.250	ED65	11.3	F33D⊙XE8D
1-1/2"	5.87	7.83	7.84	4.19	2.92	4.66	.79	1.93	1.500	ED65	16.3	G33D⊙XE8D
2"	6.85	8.70	9.10	4.60	3.66	5.88	.79	2.12	2.000	ED100	26.8	H33D⊙XE8D
60 PSI Minimum Actuator Air Supply = 6D												
1/4"	2.84	6.26	5.48	3.26	1.54	2.18	.79	1.46	.250	ED25	4.9	A33D⊙XE6D
3/8"	2.84	6.26	5.48	3.26	1.54	2.18	.79	1.46	.375	ED25	4.9	B33D⊙XE6D
1/2"	3.27	6.26	5.56	3.26	1.62	2.50	.79	1.46	.500	ED25	4.9	C33D⊙XE6D
3/4"	3.90	7.09	6.38	3.78	1.93	2.95	.79	1.70	.750	ED40	7.0	D33D⊙XE6D
1"	4.41	7.83	7.09	4.19	2.17	3.45	.79	1.93	1.000	ED65	10.3	E33D⊙XE6D
1-1/4"	4.93	8.70	7.92	4.60	2.48	3.97	.79	2.12	1.250	ED100	12.8	F33D⊙XE6D
1-1/2"	5.87	8.70	8.36	4.60	2.92	4.66	.79	2.12	1.500	ED100	17.8	G33D⊙XE6D
2"	6.85	11.14	10.08	5.39	3.66	5.88	.79	2.52	2.000	ED200	32.8	H33D⊙XE6D

© Flow Plan: **A, D, E, F, G** (see Port Arrangements diagram).

33D VALVE FEATURES

- Full port stainless steel body, ball and blow out proof stem.
- 3-way valve with investment cast body.
- NPT threaded end connection.
- RPTFE seats and seals.
- Mounting pad for direct mount.
- Temperature range: -20°F to 400°F.
- Pressure range: 29 inHg vacuum to 800 PSI.

PNEUMATIC ACTUATOR FEATURES

- E Series double acting rack and pinion actuator.
- Corrosion resistant coating.
- NAMUR solenoid mounting pad, ISO 5211 mounting standard.
- Visual position indicators.
- High duty cycle.
- Permanent lubrication.
- Temperature range: -4°F to 175°F.

33DXESR Series

Stainless steel 3-way full port ball valve with spring return pneumatic actuator
(Threaded end connection, actuators are sized for 400 PSI pressure differential)

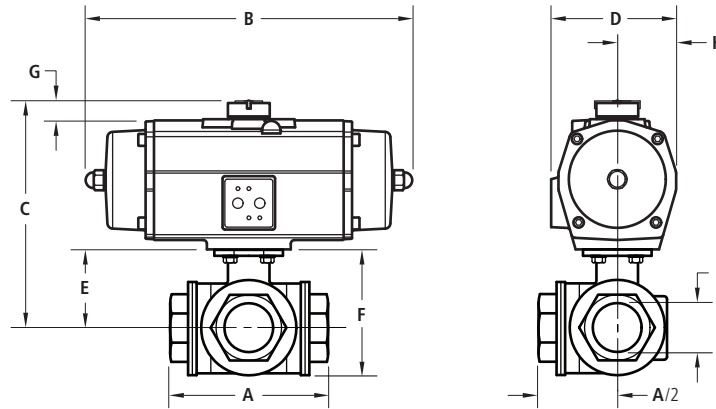

DIMENSIONS, WEIGHTS & SPECIFICATIONS

Size	A	B	C	D	E	F	G	H	I	Actuator	Wt. (lbs.)	Model No.
80 PSI Minimum Actuator Air Supply = 85												
1/4"	2.84	6.77	5.48	3.26	1.54	2.18	.79	1.46	.250	ES25	5.7	A33D⊙XE8S
3/8"	2.84	6.77	5.48	3.26	1.54	2.18	.79	1.46	.375	ES25	5.7	B33D⊙XE8S
1/2"	3.27	8.03	6.07	3.78	1.62	2.50	.79	1.70	.500	ES40	7.3	C33D⊙XE8S
3/4"	3.90	8.03	6.38	3.78	1.93	2.95	.79	1.70	.750	ES40	8.3	D33D⊙XE8S
1"	4.41	9.80	7.09	4.19	2.17	3.45	.79	1.93	1.000	ES65	12.9	E33D⊙XE8S
1-1/4"	4.93	10.51	7.92	4.60	2.48	3.97	.79	2.12	1.250	ES100	16.1	F33D⊙XE8S
1-1/2"	5.87	14.17	9.34	5.39	2.92	4.66	.79	2.52	1.500	ES200	31.1	G33D⊙XE8S
2"	6.85	14.17	10.08	5.39	3.66	5.88	.79	2.52	2.000	ES200	40.1	H33D⊙XE8S
60 PSI Minimum Actuator Air Supply = 65												
1/4"	2.84	8.03	5.99	3.78	1.54	2.18	.79	1.70	.250	ES40	7.3	A33D⊙XE6S
3/8"	2.84	8.03	5.99	3.78	1.54	2.18	.79	1.70	.375	ES40	7.3	B33D⊙XE6S
1/2"	3.27	8.03	6.07	3.78	1.62	2.50	.79	1.70	.500	ES40	7.3	C33D⊙XE6S
3/4"	3.90	8.03	6.38	3.78	1.93	2.95	.79	1.70	.750	ES40	8.3	D33D⊙XE6S
1"	4.41	10.51	7.61	4.60	2.17	3.45	.79	2.12	1.000	ES100	15.1	E33D⊙XE6S
1-1/4"	4.93	14.17	8.90	5.39	2.48	3.97	.79	2.52	1.250	ES200	26.1	F33D⊙XE6S
1-1/2"	5.87	14.17	9.34	5.39	2.92	4.66	.79	2.52	1.500	ES200	31.1	G33D⊙XE6S
2"	6.85	14.17	10.08	5.39	3.66	5.88	.79	2.52	2.000	ES200	40.1	H33D⊙XE6S

© Flow Plan: A, D, E, F, G (see Port Arrangements diagram).

33D VALVE FEATURES

- Full port stainless steel body, ball and blow out proof stem.
- 3-way valve with investment cast body.
- NPT threaded end connection.
- RPTFE seats and seals.
- Mounting pad for direct mount.
- Temperature range: -20°F to 400°F.
- Pressure range: 29 inHg vacuum to 800 PSI.

PNEUMATIC ACTUATOR FEATURES

- E Series spring return rack and pinion actuator.
- Corrosion resistant coating.
- NAMUR solenoid mounting pad, ISO 5211 mounting standard.
- Visual position indicators.
- High duty cycle.
- Permanent lubrication.
- Temperature range: -4°F to 175°F.

33DXODA Series

Stainless steel 3-way full port ball valve with double acting pneumatic actuator
(Threaded end connection, actuators are sized for 400 PSI pressure differential)

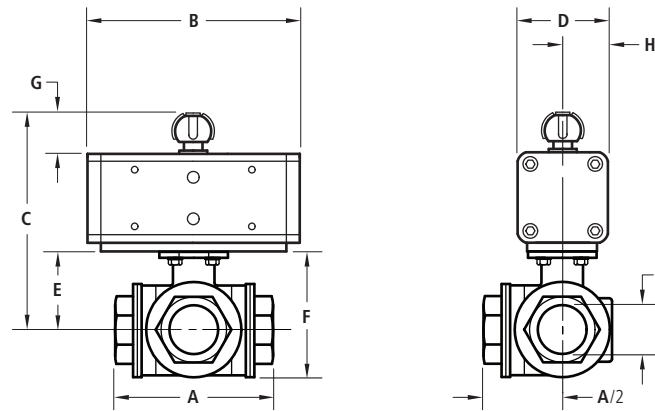

DIMENSIONS, WEIGHTS & SPECIFICATIONS

Size	A	B	C	D	E	F	G	H	I	Actuator	Wt. (lbs.)	Model No.
80 PSI Minimum Actuator Air Supply = 8D												
1/4"	2.84	5.12	4.69	2.16	1.54	2.18	.79	1.08	.250	PD030	4.2	A33D○X08D
3/8"	2.84	5.12	4.69	2.16	1.54	2.18	.79	1.08	.375	PD030	4.2	B33D○X08D
1/2"	3.27	5.12	4.77	2.16	1.62	2.50	.79	1.08	.500	PD030	4.2	C33D○X08D
3/4"	3.90	5.67	5.30	2.36	1.93	2.95	.79	1.18	.750	PD045	5.8	D33D○X08D
1"	4.41	5.67	5.54	2.36	2.17	3.45	.79	1.18	1.000	PD045	7.8	E33D○X08D
1-1/4"	4.93	6.65	6.32	2.83	2.48	3.97	.79	1.41	1.250	PD090	10.1	F33D○X08D
1-1/2"	5.87	6.65	6.76	2.83	2.92	4.66	.79	1.41	1.500	PD090	15.1	G33D○X08D
2"	6.85	8.35	8.62	3.54	3.66	5.88	1.18	1.77	2.000	PD180	27.5	H33D○X08D
60 PSI Minimum Actuator Air Supply = 6D												
1/4"	2.84	5.12	4.69	2.16	1.54	2.18	.59	1.08	.250	PD030	4.2	A33D○X06D
3/8"	2.84	5.12	4.69	2.16	1.54	2.18	.59	1.08	.375	PD030	4.2	B33D○X06D
1/2"	3.27	5.12	4.77	2.16	1.62	2.50	.59	1.08	.500	PD030	4.2	C33D○X06D
3/4"	3.90	5.67	5.30	2.36	1.93	2.95	.79	1.18	.750	PD045	5.8	D33D○X06D
1"	4.41	5.98	5.71	2.56	2.17	3.45	.79	1.28	1.000	PD060	8.4	E33D○X06D
1-1/4"	4.93	6.65	6.32	2.83	2.48	3.97	.79	1.41	1.250	PD090	10.1	F33D○X06D
1-1/2"	5.87	7.24	7.48	3.15	2.92	4.66	1.18	1.57	1.500	PD120	17.2	G33D○X06D
2"	6.85	8.35	8.62	3.54	3.66	5.88	1.18	1.77	2.000	PD180	27.5	H33D○X06D

© Flow Plan: A, D, E, F, G (see Port Arrangements diagram).

33D VALVE FEATURES

- Full port stainless steel body, ball and blow out proof stem.
- 3-way valve with investment cast body.
- NPT threaded end connection.
- RPTFE seats and seals.
- Mounting pad for direct mount.
- Temperature range: -20°F to 400°F.
- Pressure range: 29 inHg vacuum to 800 PSI.

PNEUMATIC ACTUATOR FEATURES

- O Series double acting pneumatic actuator.
- Corrosion resistant coating.
- NAMUR solenoid mounting pad, ISO 5211 mounting standard.
- Visual position indicators.
- High duty cycle.
- Permanent lubrication.
- Temperature range: -4°F to 175°F.

33DXOSR Series

Stainless steel 3-way full port ball valve with spring return pneumatic actuator
(Threaded end connection, actuators are sized for 400 PSI pressure differential)

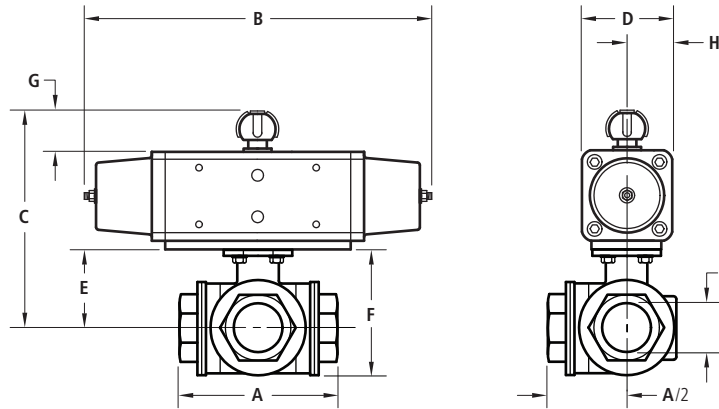

DIMENSIONS, WEIGHTS & SPECIFICATIONS

Size	A	B	C	D	E	F	G	H	I	Actuator	Wt. (lbs.)	Model No.
80 PSI Minimum Actuator Air Supply = 85												
1/4"	2.84	8.71	4.77	2.16	1.54	2.18	.79	1.08	.250	PS015	4.9	A33D⊙X08S
3/8"	2.84	8.71	4.77	2.16	1.54	2.18	.79	1.08	.375	PS015	4.9	B33D⊙X08S
1/2"	3.27	9.45	5.16	2.56	1.62	2.50	.79	1.28	.500	PS030	6.4	C33D⊙X08S
3/4"	3.90	9.45	5.47	2.56	1.93	2.95	.79	1.28	.750	PS030	7.4	D33D⊙X08S
1"	4.41	11.58	6.01	2.83	2.17	3.45	.79	1.41	1.000	PS045	10.3	E33D⊙X08S
1-1/4"	4.93	12.60	7.04	3.15	2.48	3.97	1.18	1.57	1.250	PS060	13.7	F33D⊙X08S
1-1/2"	5.87	14.06	7.88	3.54	2.92	4.66	1.18	1.77	1.500	PS090	21.1	G33D⊙X08S
2"	6.85	14.65	9.01	3.94	3.66	5.88	1.18	1.97	2.000	PS120	34.7	H33D⊙X08S
60 PSI Minimum Actuator Air Supply = 65												
1/4"	2.84	9.45	5.08	2.16	1.54	2.18	.79	1.28	.250	PS030	6.4	A33D⊙X06S
3/8"	2.84	9.45	5.08	2.16	1.54	2.18	.79	1.28	.375	PS030	6.4	B33D⊙X06S
1/2"	3.27	9.45	5.16	2.16	1.62	2.50	.79	1.28	.500	PS030	6.4	C33D⊙X06S
3/4"	3.90	9.45	5.47	2.16	1.93	2.95	.79	1.28	.750	PS030	7.4	D33D⊙X06S
1"	4.41	12.60	6.73	3.15	2.17	3.45	1.18	1.57	1.000	PS060	12.7	E33D⊙X06S
1-1/4"	4.93	14.06	7.44	3.54	2.48	3.97	1.18	1.77	1.250	PS090	16.1	F33D⊙X06S
1-1/2"	5.87	14.65	8.27	3.94	2.92	4.66	1.18	1.97	1.500	PS120	25.7	G33D⊙X06S
2"	6.85	17.18	9.48	4.41	3.66	5.88	1.18	2.20	2.000	PS180	40.7	H33D⊙X06S

© Flow Plan: A, D, E, F, G (see Port Arrangements diagram).

33D VALVE FEATURES

- Full port stainless steel body, ball and blow out proof stem.
- 3-way valve with investment cast body.
- NPT threaded end connection.
- RPTFE seats and seals.
- Mounting pad for direct mount.
- Temperature range: -20°F to 400°F.
- Pressure range: 29 inHg vacuum to 800 PSI.

PNEUMATIC ACTUATOR FEATURES

- O Series spring return pneumatic actuator.
- Corrosion resistant coating.
- NAMUR solenoid mounting pad, ISO 5211 mounting standard.
- Visual position indicators.
- High duty cycle.
- Permanent lubrication.
- Temperature range: -4°F to 175°F.

33DXK4 Series

Stainless steel 3-way full port ball valve with electric actuator, NEMA 4, 4X
(Threaded end connection, actuators are sized for 400 PSI pressure differential)

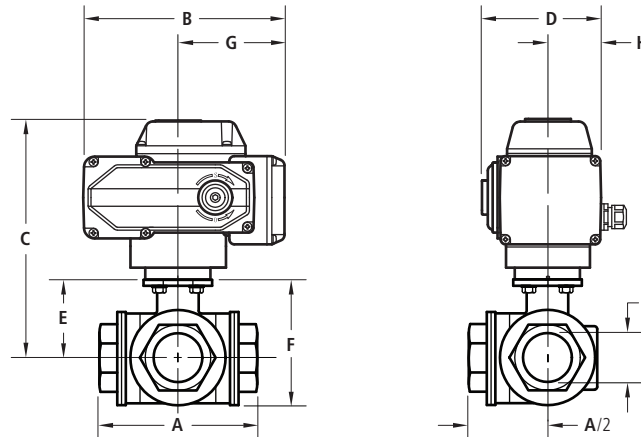

DIMENSIONS, WEIGHTS & SPECIFICATIONS

Size	A	B	C	D	E	F	G	H	I	Actuator	Wt. (lbs.)	Model No.
3/4"	3.90	8.17	8.37	4.82	1.93	2.95	4.43	2.14	0.75	KOUNIC10A-ISO	13.0	D33D⊙XK4A
1"	4.41	8.17	8.61	4.82	2.17	3.45	4.43	2.14	1.00	KOUNIC10A-ISO	15.0	E33D⊙XK4A
1-1/4"	4.93	8.17	8.92	4.82	2.48	3.97	4.43	2.14	1.25	KOUNIC10A-ISO	16.0	F33D⊙XK4A
1-1/2"	5.87	8.17	9.36	4.82	2.92	4.66	4.43	2.14	1.50	KOUNIC10A-ISO	21.0	G33D⊙XK4A
2"	6.85	8.17	10.10	4.82	3.66	5.88	4.43	2.14	2.00	KOUNIC10A-ISO	30.0	H33D⊙XK4A

© Flow Plan: **A, D, E, F, G** (see Port Arrangements diagram).

33D VALVE FEATURES

- Full port stainless steel body, ball and blow out proof stem.
- 3-way valve with investment cast body.
- NPT threaded end connection.
- RPTFE seats and seals.
- Mounting pad for direct mount.
- Temperature range: -20°F to 400°F.
- Pressure range: 29 inHg vacuum to 800 PSI.

ELECTRIC ACTUATOR FEATURES

- K Series electric actuator.
- Most voltages available.
- Quarter turn: 0-90° rotation.
- NEMA 4/4X certified by UL labs.
- ISO 5211 mounting standard.
- Visual position indicators.
- Self-locking drive train.
- Mounts in any direction.
- 1/2" NPT conduit connection.
- CSA-NRTL/C and CE certified.
- Temperature range: 0°F to 160°F.

33DXR4 Series

Stainless steel 3-way full port ball valve with electric actuator, NEMA 4, 4X
(Threaded end connection, actuators are sized for 400 PSI pressure differential)

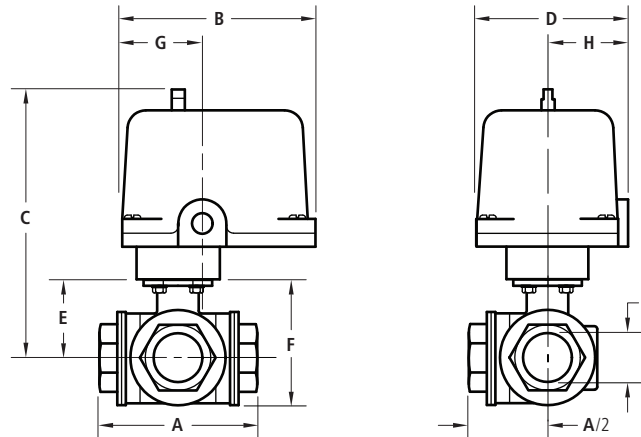

DIMENSIONS, WEIGHTS & SPECIFICATIONS

Size	A	B	C	D	E	F	G	H	I	Actuator	Wt. (lbs.)	Model No.
1/4"	2.84	5.95	7.25	4.40	1.54	2.18	2.48	2.20	.250	R150 (5 sec.)	6.0	A33D⊙XR4⊙
3/8"	2.84	5.95	7.25	4.40	1.54	2.18	2.48	2.20	.375	R150 (5 sec.)	6.0	B33D⊙XR4⊙
1/2"	3.27	5.95	7.25	4.40	1.62	2.50	2.48	2.20	.500	R150 (5 sec.)	6.0	C33D⊙XR4⊙
3/4"	3.90	5.95	7.98	4.40	1.93	2.95	2.48	2.20	.750	R300 (9 sec.)	9.0	D33D⊙XR4⊙
1"	4.41	5.95	8.22	4.40	2.17	3.45	2.48	2.20	1.000	R600 (16 sec.)	11.0	E33D⊙XR4⊙
1-1/4"	4.93	5.95	8.53	4.40	2.48	3.97	2.48	2.20	1.250	R600 (16 sec.)	17.0	F33D⊙XR4⊙
1-1/2"	5.87	5.95	8.97	4.40	2.92	4.66	2.48	2.20	1.500	R600 (16 sec.)	26.0	G33D⊙XR4⊙
2"	See K Series											

⊙ Flow Plan: A, D, E, F, G (see Port Arrangements diagram). ⊙ Voltage: A = 120 VAC; B = 24 VDC; E = 24 VAC; F = 12 VDC.

33D VALVE FEATURES

- Full port stainless steel body, ball and blow out proof stem.
- 3-way valve with investment cast body.
- NPT threaded end connection.
- RPTFE seats and seals.
- Mounting pad for direct mount.
- Temperature range: -20°F to 400°F.
- Pressure range: 29 inHg vacuum to 800 PSI.

ELECTRIC ACTUATOR FEATURES

- R Series electric actuator.
- NEMA 4, 4X.
- Voltages available: 120 VAC, 12 VDC, 24 VDC.
- Duty cycle: 25% at 120 VAC, 100% at DC units.
- ISO 5211 universal mounting.
- Manual override.
- Permanent lubrication.
- Visual position indicator.
- Temperature range: -0°F to 150°F.

33DXV4 Series

Stainless steel 3-way full port ball valve with electric actuator, NEMA 4, 4X
(Threaded end connection, actuators are sized for 400 PSI pressure differential)

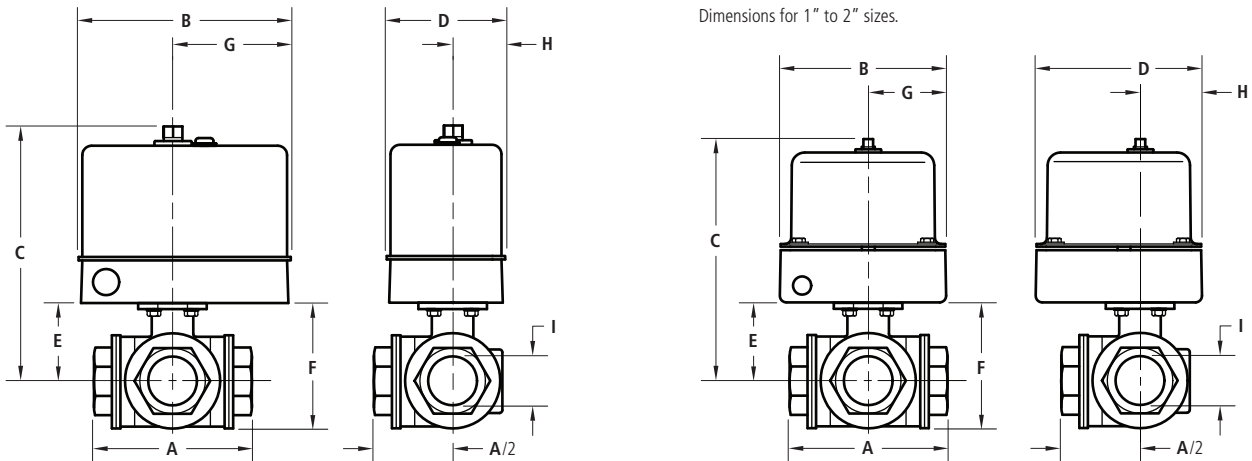

DIMENSIONS, WEIGHTS & SPECIFICATIONS

Size	A	B	C	D	E	F	G	H	I	Actuator	Wt. (lbs.)	Model No.
1/4"	2.84	5.50	5.77	3.00	1.54	2.18	3.06	1.38	.250	EV1S1V1	7.0	A31D⊙XV4⊙
3/8"	2.84	5.50	5.77	3.00	1.54	2.18	3.06	1.38	.375	EV1S1V1	7.0	B31D⊙XV4⊙
1/2"	3.27	5.50	5.85	3.00	1.62	2.50	3.06	1.38	.500	EV1S1V1	7.0	C31D⊙XV4⊙
3/4"	3.90	5.50	6.16	3.00	1.93	2.95	3.06	1.38	.750	EV1S1V1	8.0	D31D⊙XV4⊙
1"	4.41	6.43	8.49	6.43	2.17	3.45	3.01	2.63	1.000	NV6S2V1	16.0	E31D⊙XV4⊙
1-1/4"	4.93	6.43	8.80	6.43	2.48	3.97	3.01	2.63	1.250	NV6S2V1	17.0	F31D⊙XV4⊙
1-1/2"	5.87	6.43	9.24	6.43	2.92	4.66	3.01	2.63	1.500	NV6S2V1	22.0	G31D⊙XV4⊙
2"	6.85	6.43	9.98	6.43	3.66	5.88	3.01	2.63	2.000	NV1KS2V1	31.0	H31D⊙XV4⊙

⊙ Flow Plan: **A, D, E, F, G** (see Port Arrangements diagram). ⊙ Voltage: **A** = 120 VAC; **B** = 24 VDC; **C** = 220 VAC; **E** = 24 VAC; **F** = 12 VDC.

33D VALVE FEATURES

- Full port stainless steel body, ball and blow out proof stem.
- 3-way valve with investment cast body.
- NPT threaded end connection.
- RPTFE seats and seals.
- Mounting pad for direct mount.
- Temperature range: -20°F to 400°F.
- Pressure range: 29 inHg vacuum to 800 PSI.

ELECTRIC ACTUATOR FEATURES

- V Series electric actuator.
- NEMA 4, 4X.
- Voltages available: 120 VAC, 220 VAC, 24 VAC, 12 VDC, 24 VDC.
- Duty cycle: 25% at 120 VAC (EV1), 75% at 120 VAC (EV3, NV6), 100% at DC units.
- ISO 5211 universal mounting.
- Manual override.
- Permanent lubrication.
- Visual position indicator.
- Temperature range: 0°F to 160°F.