

ASSURED AUTOMATION

VA Series Valves Installation & Maintenance

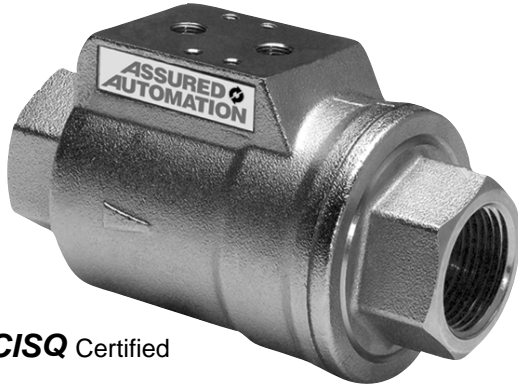

CISQ Certified

assuredautomation.com
1-800-899-0553

Functional Diagrams:

Double Acting Models

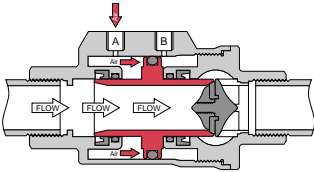

Supplying port A with air, the piston closes the valve.

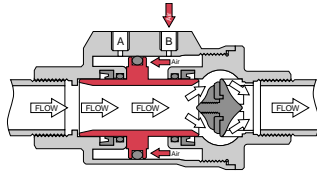

Supplying port B with air, the piston opens the valve.

Spring Return Normally Open Models

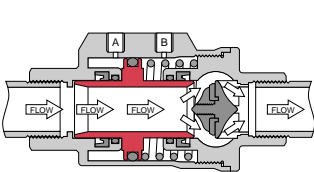

With no air supplied to either port, the spring holds the piston in the open position.

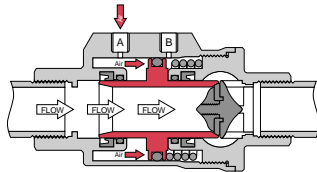

Supplying port A with air, the piston opens the valve.

Spring Return Normally Closed Models

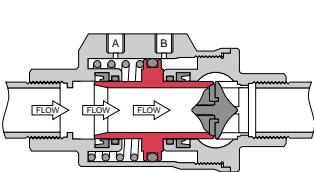

With no air supplied to either port, the spring holds the piston in the closed position.

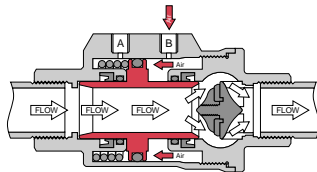

Supplying port B with air, the piston opens the valve.

Guidelines for Use

Thanks to a special design, a VA valve can be used in any mounting position, horizontal, vertical, or inclined. Even though the fluid can flow in both directions, the best possible direction will be indicated by the arrow "Flow" as shown in the Functional Diagrams.

The valve will assure a very long working life and the best result under the following operating conditions:

Control Media:

Dry, filtered compressed air, not necessarily lubricated

Pressure: 43.5 PSIG (3 bar) to 116 PSIG (8 bar) (double acting)
61 PSIG (4.2 bar) to 116 PSIG (8 bar) (spring return)

Temperature: 32°F (0°C) - to 176°F (80°C) (with lubricated air)
-4°F (-20°C) - to 176°F (80°C) (with dry air)

Operating Media:

NBR Seals: suitable for air, gas, oil. at low temperatures

Viton® Seals: suitable for most fluids, unsuitable for steam

EPDM Seals: perfectly suitable for steam and hot water.
unsuitable for mineral products (oils, greases, fuel, etc.)

Pressure: 225 PSIG (10 bar) max.

Vacuum Tightness: 740 mm Hg (mercury).

Temperature: NBR seals: -4°F to 176°F (-20°C to 80°C)
Viton® seals: -4°F to 302°F (-20°C - 150°C)
EPDM seals: -4°F to 302°F (-20°C - 150°C)

Assured Automation will not be held responsible for any damage or injury to people, things, or animals, due to improper use of the product.

Installation:

Before installing the VA valve, make sure that all tubes are free from dirt or welding residues to prevent damaging the seat seals. The valve must not be affected by tube expansions. Standard sealing means (such as PTFE, hemp, etc.) must be used on threads.

Only Use a wrench on the hexagon flats! Using a wrench on any other part may damage the valve, and cause it to function improperly.

Arrangements for Accessories:

The VA valve has been designed to be connected to a pneumatic control network through 1/8" connections for NAMUR solenoid valves. Magnetic limit switches may be mounted on the valve. They are supplied with their mounting kit for quick and easy installation.

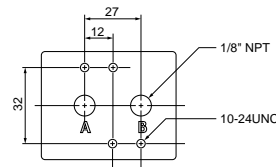

Magnetic Limit Switch

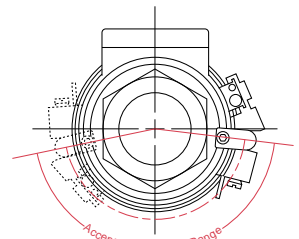
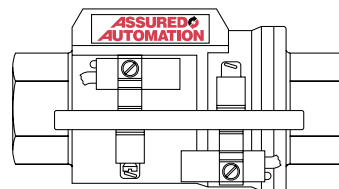

Assured Automation reserves the right to make changes to the information provided in this manual at any time.

Maintenance:

If you use a VA valve properly, and in accordance with the instructions listed under the *Guidelines for Use* section, it will be maintenance free. However, should it be necessary to replace any part, that will be easily done, by any member of your staff without any special training or equipment.



Before Proceeding!

1. Check the nature of the fluid flowing into the VA valve since it might be corrosive, toxic, inflammable, polluting, or dangerous.
2. Before disassembling the VA valve, make sure that the air, and the electric supplies are completely disconnected, both up and down the valve. All taps next to the VA valve should be kept closed during maintenance procedures.
3. Before handling the VA valve, take the following safety precautions:
 - Put on a pair of protective glasses or a safety visor
 - Put on a pair of gloves, an overall, and safety helmet
 - Make sure that running water is at hand
 - Make sure that a fire extinguisher is at hand. If the fluid is inflammable, the extinguisher will have to be suitable for it.

Seal Replacement

All spare parts needed for a VA overhaul will be provided in the "Spare Kit". If you want to order a "Spare Kit", you will have to give its code or the VA DN printed on the label and the seal material.

The Contents for Spare Kits are noted with an asterisk (*) in the parts list table below. If other parts are needed, you may need to replace the entire valve. Contact Assured Automation for more information.

Replacement Parts

Part	Description	Materials	No. of Pieces	
			Double Acting	Spring Return
1	Body	Brass (Nickel Plated)	1	1
2	Piston	Brass (Nickel Plated)	1	1
3*	Lip Seals	NBR / Viton / EPDM	2	2
4*	Stem O-ring	NBR / Viton	2	2
5	Spring (N.O. / N.C.)	Steel	-	1
6*	Seat Seal	NBR / Viton / EPDM	1	1
7	Sleeve	Brass (Nickel Plated)	1	1
8	Seat	Brass (Nickel Plated)	1	1
9*	Sleeve O-ring	NBR / Viton	1	1
10	Seat Nut	Brass (Nickel Plated)	1	1
11*	Piston O-ring	NBR / Viton	1	1

* Parts marked with an asterisk (*) are included in Seal Kits.

Size	Seal Kit Part Numbers		
	NBR (Buna)	Viton®	EPDM
037	RKVA037BB	RKVA037VV	RKVA037EE
050	RKVA050BB	RKVA050VV	RKVA050EE
075	RKVA075BB	RKVA075VV	RKVA075EE
100	RKVA100BB	RKVA100VV	RKVA100EE
125	RKVA125BB	RKVA125VV	RKVA125EE
150	RKVA150BB	RKVA150VV	RKVA150EE
200	RKVA200BB	RKVA200VV	RKVA200EE

Disassembling The Valve

1. Unscrew the sleeve (part 7). With Normally Open, or Normally Closed executions, pay attention to the pressure of the springs (part 5)
2. Remove the piston (part 2) and all of the seals; clean everything carefully, and replace the parts. If you want to replace the seat seal (part 6) unscrew the nut (part 10) counter clockwise, replace the seal and reassemble the parts putting glue "Nm 045" on the thread.

Parts Diagram

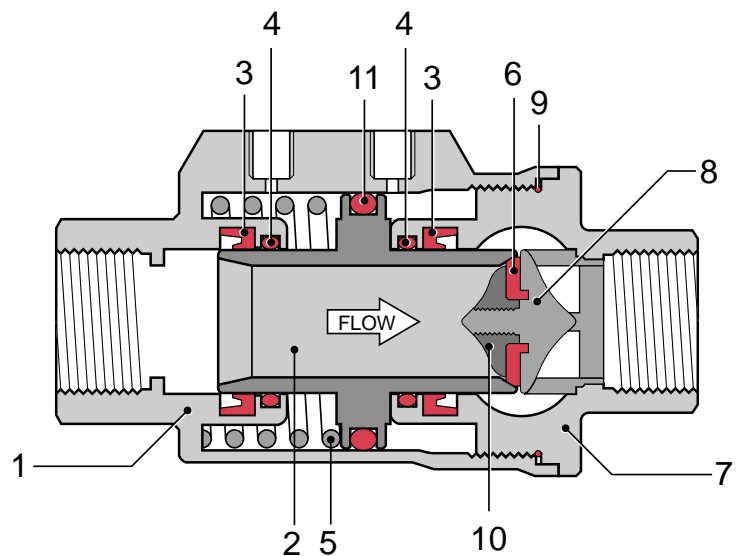

Breather filter for open port on spring return models
Part Number: ADBV-18