

PBV Series

PVC / CPVC 2-way Full Port Plastic Ball Valve



The PBV is a full port, PVC or CPVC thermoplastic automated ball valve supplied with NPT, socket weld or 150 lb. flanged end caps. The double union design permits easy installation and removal for maintenance. The body has metal threaded mounting inserts for actuator assembly. The PBV product line can be equipped with a manual handle or with pneumatic or electric actuators.

A full range of accessory items are available including limit switches, solenoid valves, positioners and manual override devices.

FEATURES

- Full port for unobstructed flow.
- Blow-out proof stem.
- Mounting pad with metal inserts for actuator.
- Double union design.
- Compact assembly.
- Valve can be rotated for actuator clearance.
- Complete line of accessories.

TYPICAL APPLICATIONS

- Seawater and corrosive liquids.
- Pollution control equipment.
- Process control applications.
- Laundry equipment.
- Textile dyeing and drying.
- Bottle dispensing.
- Ink and paint dispensing.
- Chemical process equipment.

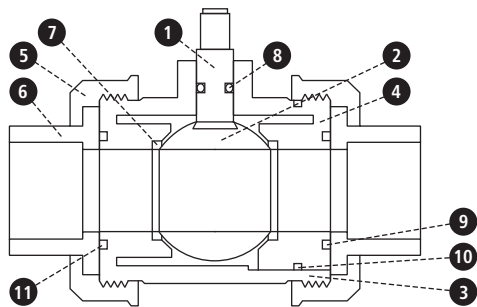

ACTUATOR CONFIGURATIONS

- Electric.
- Pneumatic (spring return).
- Pneumatic (double acting).
- Manual handle.

PRESSURE RANGE

29 inHg vacuum to 150 PSI

TEMPERATURE RANGE

0°F to 140°F (PVC)
0°F to 200°F (CPVC)

SPECIFICATIONS

End Connections and Standards:

- NPT Threaded:
ASTM D-2464 (PVC, SCH-80)
ASTM F-437 (CPVC, SCH-80)
- Socket:
ASTM D-2467 (PVC, SCH-80)
ASTM F-439 (CPVC, SCH-80)
- Flanged:
ANSI B16.5 Class 150

Note: Not recommended for compressed air or gas services.

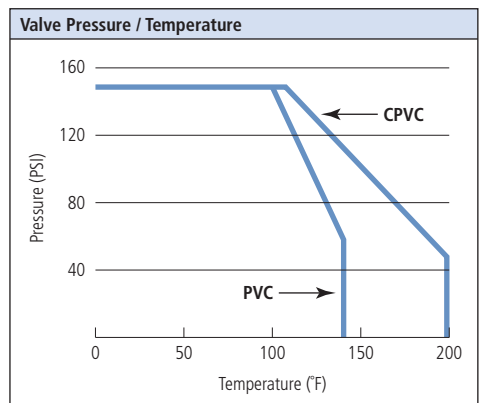

MATERIALS OF CONSTRUCTION

Part	Qty.	Description	Standard Material
1	1	Stem	PVC, CPVC
2	1	Ball	PVC, CPVC
3	1	Body	PVC, CPVC
4	1	Seat Carrier	PVC, CPVC
5	2	Union Nut	PVC, CPVC
6	2	End Connector	PVC, CPVC
7	2	Seat	Teflon®
8	1	Stem O-Ring	EPDM, Viton®
9	1	Seat Carrier O-Ring	EPDM, Viton®
10	1	Body End O-Ring	EPDM, Viton®
11	1	Solid End O-Ring	EPDM, Viton®

CV FACTORS

Size	CV
1/2"	14
3/4"	30
1"	44
1-1/4"	80
1-1/2"	130
2"	185
3"	450
4"	730

PBVM Series

PVC / CPVC 2-way full port plastic ball valve with manual handle

(Threaded, socket and 150 lb. flanged end connection)

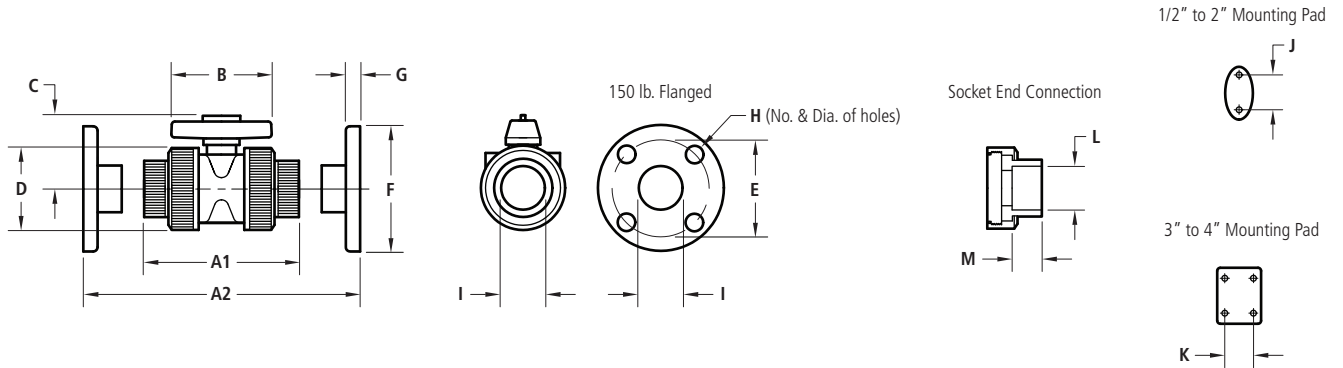

DIMENSIONS, WEIGHTS & SPECIFICATIONS

Size	A1	A2	B	C	D	E	F	G	H	I	J	K	L	M	Wt. (lbs.)		Model No.
															N & S	F	
1/2"	4.42	6.02	3.24	2.12	2.11	2.38	3.50	.59	(4) .62	.59	1.22	-	.840	.88	.63	1.0	CPB○○○M
3/4"	4.84	6.67	3.97	2.53	2.50	2.75	3.88	.59	(4) .62	.80	1.45	-	1.050	1.00	1.0	1.6	DPB○○○M
1"	5.62	7.77	4.39	2.81	2.87	3.12	4.25	.63	(4) .62	1.02	1.57	-	1.315	1.12	1.0	2.0	EPB○○○M
1-1/2"	7.16	9.28	4.78	3.34	3.85	3.88	5.00	.63	(4) .62	1.50	2.16	-	1.900	1.38	3.0	4.2	GPB○○○M
2"	7.95	10.15	5.88	3.85	4.73	4.75	6.00	.78	(4) .75	1.89	2.67	-	2.375	1.50	4.4	6.4	HPB○○○M
3"	10.83	11.54	9.05	6.54	7.20	6.00	7.50	.79	(4) .75	3.15	-	1.75	3.516	1.88	12.6	16.4	JPB○○○M
4"	12.80	15.18	10.79	6.69	8.90	7.50	9.00	.87	(4) .75	4.02	-	1.93	4.518	2.25	17.8	22.6	KPB○○○M

© Valve Material: P = PVC; C = CPVC. © Seal Material: E = EPDM; V = Viton®. © End Connection: N = NPT; S = Glued Socket; F = 150 lb. Flanged.

PBV VALVE FEATURES

- Full port PVC/CPVC body and ball.
- Blow out proof stem.
- PTFE seats, Viton® or EPDM stem and body seals.
- Mounting pad for mounting actuator.
- Temperature range: 0°F to 140°F (PVC), 0°F to 200°F (CPVC).
- Pressure range: 29 inHg vacuum to 150 PSI.
- NSF14/NSF61 approved.

PBVEDA Series

PVC / CPVC 2-way full port plastic ball valve with double acting pneumatic actuator
(Threaded, socket and 150 lb. flanged end connection, actuators are sized for 150 PSI pressure differential)

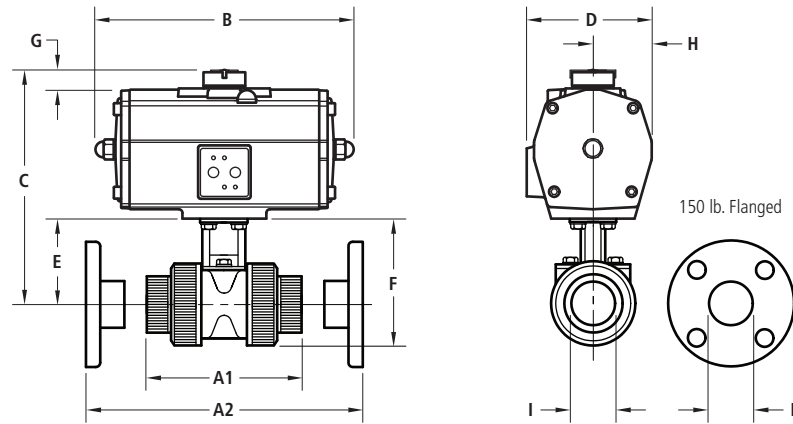

DIMENSIONS, WEIGHTS & SPECIFICATIONS

Size	A1	A2	B	C	D	E	F	G	H	I	Actuator	Wt.*(lbs.)	Model No.
80 PSI Minimum Actuator Air Supply = 8D													
1/2"	4.42	6.02	6.26	5.99	3.26	2.05	3.09	.79	1.46	.59	EDA25	3.5	CPB⊙⊙⊙E8D
3/4"	4.84	6.67	6.26	6.70	3.26	2.76	4.02	.79	1.46	.80	EDA25	3.9	DPB⊙⊙⊙E8D
1"	5.62	7.77	6.26	6.88	3.26	2.94	4.37	.79	1.46	1.02	EDA25	4.2	EPB⊙⊙⊙E8D
1-1/2"	7.16	9.28	7.09	8.51	3.78	4.06	5.99	.79	1.70	1.50	EDA40	7.0	GPB⊙⊙⊙E8D
2"	7.95	10.15	7.09	8.88	3.78	4.43	6.74	.79	1.70	1.89	EDA40	8.4	HPB⊙⊙⊙E8D
3"	10.83	11.54	7.83	11.46	4.19	6.54	10.10	.79	1.93	3.15	EDA65	17.9	JPB⊙⊙⊙E8D
4"	12.80	15.18	8.70	12.83	4.60	7.39	11.80	.79	2.12	4.02	EDA100	24.6	KPB⊙⊙⊙E8D
60 PSI Minimum Actuator Air Supply = 6D													
1/2"	4.42	6.02	9.45	5.99	2.36	2.05	3.09	.79	1.18	.59	EDA25	3.5	CPB⊙⊙⊙E6D
3/4"	4.84	6.67	9.45	6.70	2.36	2.76	4.02	.79	1.18	.80	EDA25	3.9	DPB⊙⊙⊙E6D
1"	5.62	7.77	11.58	6.88	2.83	2.94	4.37	.79	1.41	1.02	EDA25	4.2	EPB⊙⊙⊙E6D
1-1/2"	7.16	9.28	11.58	8.51	2.83	4.06	5.99	.79	1.41	1.50	EDA40	7.0	GPB⊙⊙⊙E6D
2"	7.95	10.15	12.60	8.88	2.83	4.43	6.74	.79	1.41	1.89	EDA40	8.4	HPB⊙⊙⊙E6D
3"	10.83	11.54	17.18	11.94	2.83	6.54	10.10	.79	1.41	3.15	EDA100	19.4	JPB⊙⊙⊙E6D
4"	12.80	15.18	17.18	13.81	3.15	7.39	11.80	.79	1.57	4.02	EDA200	30.6	KPB⊙⊙⊙E6D

⊙ Valve Material: **P** = PVC; **C** = CPVC. ⊙ Seal Material: **E** = EPDM; **V** = Viton®. ⊙ End Connection: **N** = NPT; **S** = Glued Socket; **F** = 150 lb. Flanged.
* Weight is for NPT and socket valves only. See manual valve drawing (PBVM) for flanged valve weight difference and additional valve dimensions.

PBV VALVE FEATURES

- Full port PVC/CPVC body and ball.
- Blow out proof stem.
- PTFE seats, Viton® or EPDM stem and body seals.
- Mounting pad for mounting actuator.
- Temperature range: 0°F to 140°F (PVC), 0°F to 200°F (CPVC).
- Pressure range: 29 inHg vacuum to 150 PSI.
- NSF14/NSF61 approved.

PNEUMATIC ACTUATOR FEATURES

- E Series double acting rack and pinion actuator.
- Corrosion resistant coating.
- NAMUR solenoid mounting pad, ISO 5211 mounting standard.
- Visual position indicators.
- High duty cycle.
- Permanent lubrication.
- Temperature range: -4°F to 175°F.

PBVESR Series

PVC / CPVC 2-way full port plastic ball valve with spring return pneumatic actuator
(Threaded, socket and 150 lb. flanged end connection, actuators are sized for 150 PSI pressure differential)

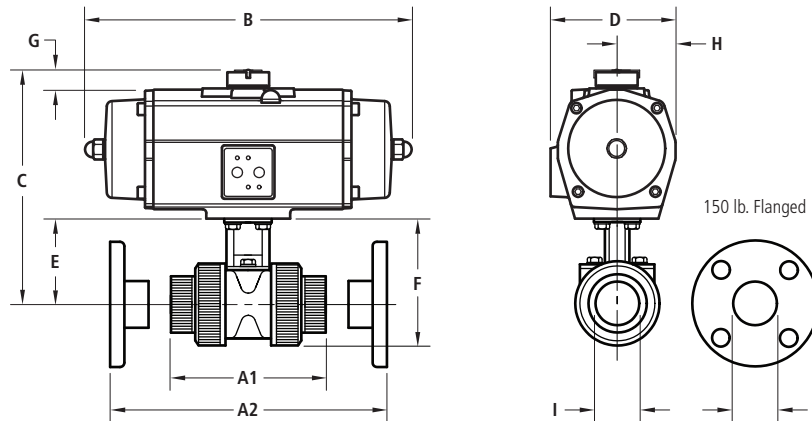

DIMENSIONS, WEIGHTS & SPECIFICATIONS

Size	A1	A2	B	C	D	E	F	G	H	I	Actuator	Wt.*(lbs.)	Model No.
80 PSI Minimum Actuator Air Supply = 85													
1/2"	4.42	6.02	6.77	5.99	3.26	2.05	3.09	.79	1.46	.59	ES25-4	4.3	CPB○○○○E8S
3/4"	4.84	6.67	6.77	6.70	3.26	2.76	4.02	.79	1.46	.80	ES25-4	4.7	DPB○○○○E8S
1"	5.62	7.77	6.77	6.88	3.26	2.94	4.37	.79	1.46	1.02	ES25-4	5.0	EPB○○○○E8S
1-1/2"	7.16	9.28	8.03	8.51	3.78	4.06	5.99	.79	1.70	1.50	ES40-4	8.3	GPB○○○○E8S
2"	7.95	10.15	9.80	9.35	4.19	4.43	6.74	.79	1.93	1.89	ES60-4	12.3	HPB○○○○E8S
3"	10.83	11.54	10.51	11.98	4.60	6.54	10.10	.79	2.12	3.15	ES100-4	22.7	JPB○○○○E8S
4"	12.80	15.18	14.17	13.81	5.39	7.39	11.80	.79	2.52	4.02	ES200-4	37.9	KPB○○○○E8S
60 PSI Minimum Actuator Air Supply = 65													
1/2"	4.42	6.02	6.77	5.99	3.26	2.05	3.09	.79	1.46	.59	ES25-4	4.3	CPB○○○○E6S
3/4"	4.84	6.67	6.77	6.70	3.26	2.76	4.02	.79	1.46	.80	ES25-4	4.7	DPB○○○○E6S
1"	5.62	7.77	6.77	6.88	3.26	2.94	4.37	.79	1.46	1.02	ES25-4	5.0	EPB○○○○E6S
1-1/2"	7.16	9.28	9.80	8.98	4.19	4.06	5.99	.79	1.93	1.50	ES65-4	10.9	GPB○○○○E6S
2"	7.95	10.15	9.80	9.35	4.19	4.43	6.74	.79	1.93	1.89	ES65-4	12.3	HPB○○○○E6S
3"	10.83	11.54	14.17	12.96	5.39	6.54	10.10	.79	2.52	3.15	ES200-4	32.7	JPB○○○○E6S
4"	12.80	15.18	14.17	13.81	5.39	7.39	11.80	.79	2.52	4.02	ES200-4	37.9	KPB○○○○E6S

⊙ Valve Material: **P** = PVC; **C** = CPVC. ⊙ Seal Material: **E** = EPDM; **V** = Viton®. ⊙ End Connection: **N** = NPT; **S** = Glued Socket; **F** = 150 lb. Flanged.
* Weight is for NPT and socket valves only. See manual valve drawing (PBVM) for flanged valve weight difference and additional valve dimensions.

PBV VALVE FEATURES

- Full port PVC/CPVC body and ball.
- Blow out proof stem.
- PTFE seats, Viton® or EPDM stem and body seals.
- Mounting pad for mounting actuator.
- Temperature range: 0°F to 140°F (PVC), 0°F to 200°F (CPVC).
- Pressure range: 29 inHg vacuum to 150 PSI.
- NSF14/NSF61 approved.

PNEUMATIC ACTUATOR FEATURES

- E Series spring return rack and pinion actuator.
- Corrosion resistant coating.
- NAMUR solenoid mounting pad, ISO 5211 mounting standard.
- Visual position indicators.
- High duty cycle.
- Permanent lubrication.
- Temperature range: -4°F to 175°F.

PBVODA Series

PVC / CPVC 2-way full port plastic ball valve with double acting pneumatic actuator
(Threaded, socket and 150 lb. flanged end connection, actuators are sized for 150 PSI pressure differential)

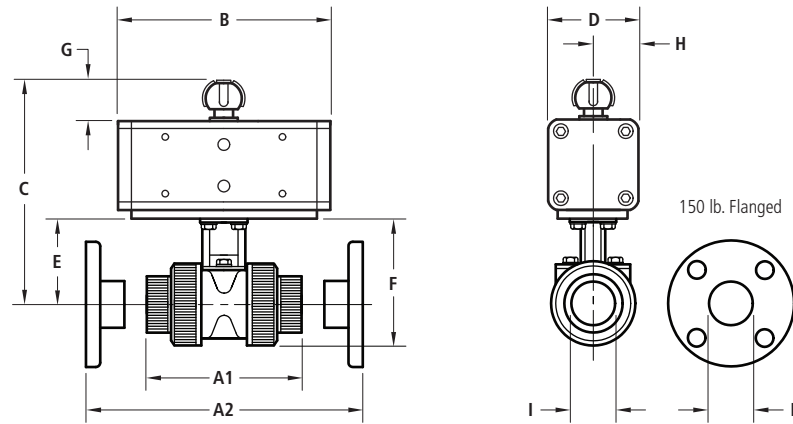

DIMENSIONS, WEIGHTS & SPECIFICATIONS

Size	A1	A2	B	C	D	E	F	G	H	I	Actuator	Wt.*(lbs.)	Model No.
80 PSI Minimum Actuator Air Supply = 8D													
1/2"	4.42	6.02	5.12	5.20	2.16	2.05	3.09	.79	1.08	.59	PS030	2.8	CPB⊙⊙⊙08D
3/4"	4.84	6.67	5.12	5.91	2.16	2.76	4.02	.79	1.08	.80	PS030	3.2	DPB⊙⊙⊙08D
1"	5.62	7.77	5.12	6.09	2.16	2.94	4.37	.79	1.08	1.02	PS030	3.5	EPB⊙⊙⊙08D
1-1/2"	7.16	9.28	5.12	7.21	2.16	4.06	5.99	.79	1.08	1.50	PS030	5.2	GPB⊙⊙⊙08D
2"	7.95	10.15	5.67	7.80	2.36	4.43	6.74	.79	1.18	1.89	PS045	7.2	HPB⊙⊙⊙08D
3"	10.83	11.54	5.67	9.91	2.36	6.54	10.10	.79	1.18	3.15	PS045	15.4	JPB⊙⊙⊙08D
4"	12.80	15.18	6.65	11.23	2.83	7.39	11.80	.79	1.41	4.02	PS090	21.9	KPB⊙⊙⊙08D
60 PSI Minimum Actuator Air Supply = 6D													
1/2"	4.42	6.02	9.45	5.42	2.36	2.05	3.09	.79	1.18	.59	PS045	3.4	CPB⊙⊙⊙06D
3/4"	4.84	6.67	9.45	6.13	2.36	2.76	4.02	.79	1.18	.80	PS045	3.8	DPB⊙⊙⊙06D
1"	5.62	7.77	11.58	6.78	2.83	2.94	4.37	.79	1.41	1.02	PS090	5.4	EPB⊙⊙⊙06D
1-1/2"	7.16	9.28	11.58	7.90	2.83	4.06	5.99	.79	1.41	1.50	PS090	7.1	GPB⊙⊙⊙06D
2"	7.95	10.15	12.60	8.27	2.83	4.43	6.74	.79	1.41	1.89	PS090	8.5	HPB⊙⊙⊙06D
3"	10.83	11.54	17.18	10.38	2.83	6.54	10.10	.79	1.41	3.15	PS090	16.7	JPB⊙⊙⊙06D
4"	12.80	15.18	17.18	11.95	3.15	7.39	11.80	.79	1.57	4.02	PS120	24.0	KPB⊙⊙⊙06D

⊙ Valve Material: **P** = PVC; **C** = CPVC. ⊙ Seal Material: **E** = EPDM; **V** = Viton®. ⊙ End Connection: **N** = NPT; **S** = Glued Socket; **F** = 150 lb. Flanged.
* Weight is for NPT and socket valves only. See manual valve drawing (PBVM) for flanged valve weight difference and additional valve dimensions.

PBV VALVE FEATURES

- Full port PVC/CPVC body and ball.
- Blow out proof stem.
- PTFE seats, Viton® or EPDM stem and body seals.
- Mounting pad for mounting actuator.
- Temperature range: 0°F to 140°F (PVC), 0°F to 200°F (CPVC).
- Pressure range: 29 inHg vacuum to 150 PSI.
- NSF14/NSF61 approved.

PNEUMATIC ACTUATOR FEATURES

- O Series double acting pneumatic actuator.
- Corrosion resistant coating.
- NAMUR solenoid mounting pad, ISO 5211 mounting standard.
- Visual position indicators.
- High duty cycle.
- Permanent lubrication.
- Temperature range: -4°F to 175°F.

PBVOSR Series

PVC / CPVC 2-way full port plastic ball valve with spring return pneumatic actuator
(Threaded, socket and 150 lb. flanged end connection, actuators are sized for 150 PSI pressure differential)

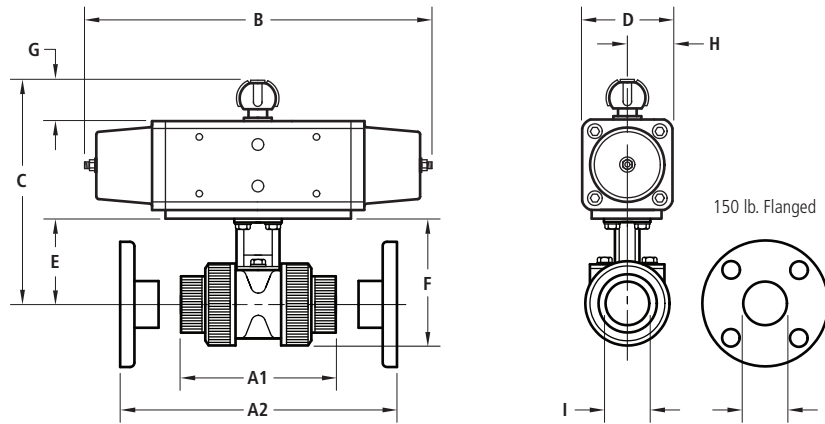

DIMENSIONS, WEIGHTS & SPECIFICATIONS

Size	A1	A2	B	C	D	E	F	G	H	I	Actuator	Wt.*(lbs.)	Model No.
80 PSI Minimum Actuator Air Supply = 85													
1/2"	4.42	6.02	5.12	5.20	2.16	2.05	3.09	.79	1.08	.59	PS030	5.0	CPB○○○○08S
3/4"	4.84	6.67	5.12	5.91	2.16	2.76	4.02	.79	1.08	.80	PS030	5.4	DPB○○○○08S
1"	5.62	7.77	5.12	6.09	2.16	2.94	4.37	.79	1.08	1.02	PS030	6.6	EPB○○○○08S
1-1/2"	7.16	9.28	5.12	7.21	2.16	4.06	5.99	.79	1.08	1.50	PS030	8.3	GPB○○○○08S
2"	7.95	10.15	5.67	7.80	2.36	4.43	6.74	.79	1.18	1.89	PS045	9.7	HPB○○○○08S
3"	10.83	11.54	5.67	9.91	2.36	6.54	10.10	.79	1.18	3.15	PS045	33.3	JPB○○○○08S
4"	12.80	15.18	6.65	11.23	2.83	7.39	11.80	.79	1.41	4.02	PS090	38.5	KPB○○○○08S
60 PSI Minimum Actuator Air Supply = 65													
1/2"	4.42	6.02	9.45	5.42	2.36	2.05	3.09	.79	1.18	.59	PS045	5.0	CPB○○○○06S
3/4"	4.84	6.67	9.45	6.13	2.36	2.76	4.02	.79	1.18	.80	PS045	5.4	DPB○○○○06S
1"	5.62	7.77	11.58	6.78	2.83	2.94	4.37	.79	1.41	1.02	PS090	6.6	EPB○○○○06S
1-1/2"	7.16	9.28	11.58	7.90	2.83	4.06	5.99	.79	1.41	1.50	PS090	8.3	GPB○○○○06S
2"	7.95	10.15	12.60	8.27	2.83	4.43	6.74	.79	1.41	1.89	PS090	12.1	HPB○○○○06S
3"	10.83	11.54	17.18	10.38	2.83	6.54	10.10	.79	1.41	3.15	PS090	33.3	JPB○○○○06S
4"	12.80	15.18	17.18	11.95	3.15	7.39	11.80	.79	1.57	4.02	PS120	38.5	KPB○○○○06S

○ Valve Material: **P** = PVC; **C** = CPVC. ○ Seal Material: **E** = EPDM; **V** = Viton®. ○ End Connection: **N** = NPT; **S** = Glued Socket; **F** = 150 lb. Flanged.
* Weight is for NPT and socket valves only. See manual valve drawing (PBVM) for flanged valve weight difference and additional valve dimensions.

PBV VALVE FEATURES

- Full port PVC/CPVC body and ball.
- Blow out proof stem.
- PTFE seats, Viton® or EPDM stem and body seals.
- Mounting pad for mounting actuator.
- Temperature range: 0°F to 140°F (PVC), 0°F to 200°F (CPVC).
- Pressure range: 29 inHg vacuum to 150 PSI.
- NSF14/NSF61 approved.

PNEUMATIC ACTUATOR FEATURES

- O Series spring return pneumatic actuator.
- Corrosion resistant coating.
- NAMUR solenoid mounting pad, ISO 5211 mounting standard.
- Visual position indicators.
- High duty cycle.
- Permanent lubrication.
- Temperature range: -4°F to 175°F.

PBVR4 Series

PVC / CPVC 2-way full port plastic ball valve with electric actuator, NEMA 4, 4X

(Threaded, socket and 150 lb. flanged end connection, actuators are sized for 150 PSI pressure differential)

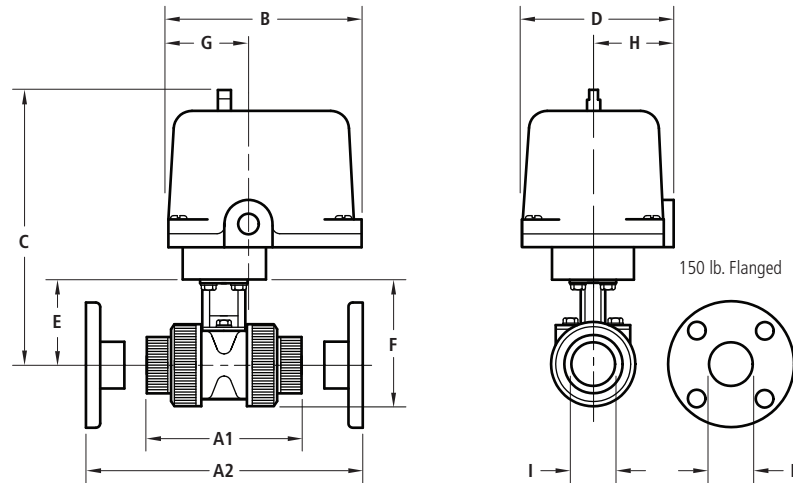

DIMENSIONS, WEIGHTS & SPECIFICATIONS

Size	A1	A2	B	C	D	E	F	G	H	I	Actuator	Wt.* (lbs.)	Model No.
1/2"	4.42	6.02	5.95	8.10	4.40	2.05	3.09	2.48	2.20	.59	R300 (9 sec.)	6.6	CPB⊙⊙⊙R4⊙
3/4"	4.84	6.67	5.95	8.81	4.40	2.76	4.02	2.48	2.20	.80	R300 (9 sec.)	7.0	DPB⊙⊙⊙R4⊙
1"	5.62	7.77	5.95	8.99	4.40	2.94	4.37	2.48	2.20	1.02	R300 (9 sec.)	7.3	EPB⊙⊙⊙R4⊙
1-1/2"	7.16	9.28	5.95	10.11	4.40	4.06	5.99	2.48	2.20	1.50	R600 (16 sec.)	9.0	GPB⊙⊙⊙R4⊙
2"	7.95	10.15	5.95	10.48	4.40	4.43	6.74	2.48	2.20	1.89	R600 (16 sec.)	10.4	HPB⊙⊙⊙R4⊙
3"	See I4 Series												
4"	See I4 Series												

⊙ Valve Material: **P** = PVC; **C** = CPVC. ⊙ Seal Material: **E** = EPDM; **V** = Viton®. ⊙ End Connection: **N** = NPT; **S** = Glued Socket; **F** = 150 lb. Flanged. ⊙ Voltage: **A** = 120 VAC; **B** = 24 VDC; **F** = 12 VDC.
* Weight is for NPT and socket valves only. See manual valve drawing (PBVM) for flanged valve weight difference and additional valve dimensions.

PBV VALVE FEATURES

- Full port PVC/CPVC body and ball.
- Blow out proof stem.
- PTFE seats, Viton® or EPDM stem and body seals.
- Mounting pad for mounting actuator.
- Temperature range: 0°F to 140°F (PVC), 0°F to 200°F (CPVC).
- Pressure range: 29 inHg vacuum to 150 PSI.
- NSF14/NSF61 approved.

ELECTRIC ACTUATOR FEATURES

- R Series electric actuator.
- NEMA 4, 4X.
- Voltages available: 120 VAC, 12 VDC, 24 VDC.
- Duty cycle: 25% at 120 VAC, 100% at DC units.
- ISO 5211 universal mounting.
- Manual override.
- Permanent lubrication.
- Visual position indicator.
- Temperature range: 0°F to 150°F.

PBVV4 Series

PVC / CPVC 2-way full port plastic ball valve with electric actuator, NEMA 4, 4X

(Threaded, socket and 150 lb. flanged end connection, actuators are sized for 150 PSI pressure differential)

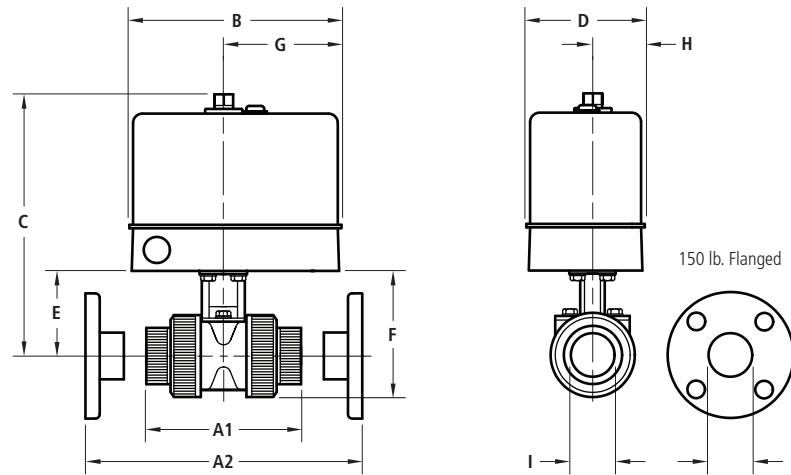

DIMENSIONS, WEIGHTS & SPECIFICATIONS

Size	A1	A2	B	C	D	E	F	G	H	I	Actuator	Wt.* (lbs.)	Model No.
1/2"	4.42	6.02	5.50	6.28	3.00	2.05	3.09	3.06	1.38	.59	EV1S1V1	5.6	CPB⊙⊙⊙V4⊙
3/4"	4.84	6.67	5.50	6.99	3.00	2.76	4.02	3.06	1.38	.80	EV1S1V1	6.0	DPB⊙⊙⊙V4⊙
1"	5.62	7.77	5.50	7.17	3.00	2.94	4.37	3.06	1.38	1.02	EV3S1V1	6.3	EPB⊙⊙⊙V4⊙
1-1/2"	7.16	9.28	5.50	8.29	3.00	4.06	5.99	3.06	1.38	1.50	EV3S1V1	8.0	GPB⊙⊙⊙V4⊙
2"	7.95	10.15	5.50	8.66	3.00	4.43	6.74	3.06	1.38	1.89	EV3S1V1	9.4	HPB⊙⊙⊙V4⊙
3"	See I4 Series												
4"	See I4 Series												

⊙ Valve Material: **P** = PVC; **C** = CPVC. ⊙ Seal Material: **E** = EPDM; **V** = Viton®. ⊙ End Connection: **N** = NPT; **S** = Glued Socket; **F** = 150 lb. Flanged.
 ⊙ Voltage: **A** = 120 VAC; **B** = 24 VDC; **C** = 220 VAC; **E** = 24 VAC; **F** = 12 VDC.

* Weight is for NPT and socket valves only. See manual valve drawing (PBVM) for flanged valve weight difference and additional valve dimensions.

PBV VALVE FEATURES

- Full port PVC/CPVC body and ball.
- Blow out proof stem.
- PTFE seats, Viton® or EPDM stem and body seals.
- Mounting pad for mounting actuator.
- Temperature range: 0°F to 140°F (PVC), 0°F to 200°F (CPVC).
- Pressure range: 29 inHg vacuum to 150 PSI.
- NSF14/NSF61 approved.

ELECTRIC ACTUATOR FEATURES

- V Series electric actuator.
- NEMA 4, 4X.
- Voltages available: 120 VAC, 220 VAC, 24 VAC, 12 VDC, 24VDC.
- Duty cycle: 25% at 120 VAC (EV1), 75% at 120 VAC (EV3, NV6), 100% at DC units.
- ISO 5211 universal mounting.
- Manual override.
- Permanent lubrication.
- Visual position indicator.
- Temperature range: 0°F to 160°F.

PBVI4 Series

PVC / CPVC 2-way full port plastic ball valve with electric actuator, NEMA 4, 4X

(Threaded, socket and 150 lb. flanged end connection, actuators are sized for 150 PSI pressure differential)

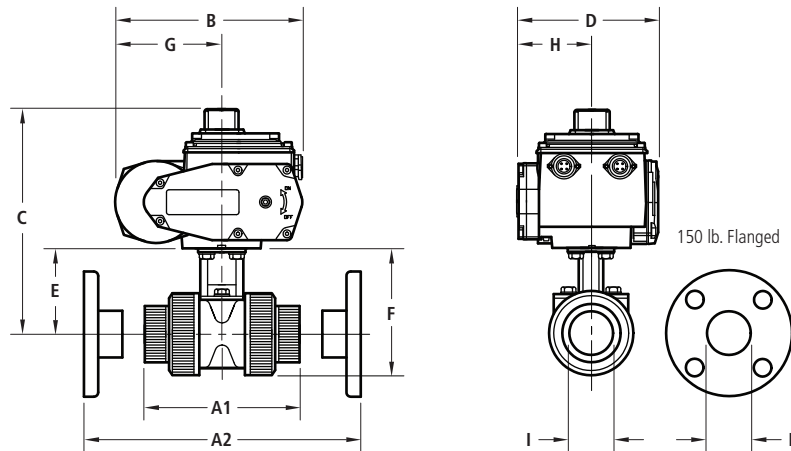

DIMENSIONS, WEIGHTS & SPECIFICATIONS

Size	A1	A2	B	C	D	E	F	G	H	I	Actuator	Wt.* (lbs.)	Model No.
2"	7.95	10.15	7.56	9.82	5.36	4.43	6.74	3.58	2.37	1.89	I4600	12.3	HPB○○○○I4○
3"	10.83	11.54	7.56	11.93	5.36	6.54	10.10	3.58	2.37	3.15	I4600	20.5	JPB○○○○I4○
4"	12.80	15.18	7.56	12.78	5.36	7.39	11.80	3.58	2.37	4.02	I4600	25.7	KPB○○○○I4○

○ Valve Material: **P** = PVC; **C** = CPVC. ○ Seal Material: **E** = EPDM; **V** = Viton®. ○ End Connection: **N** = NPT; **S** = Glued Socket; **F** = 150 lb. Flanged. ○ Voltage: **A** = 120 VAC; **B** = 24 VDC; **F** = 12 VDC.
* Weight is for NPT and socket valves only. See manual valve drawing (PBVM) for flanged valve weight difference and additional valve dimensions.

PBV VALVE FEATURES

- Full port PVC/CPVC body and ball.
- Blow out proof stem.
- PTFE seats, Viton® or EPDM stem and body seals.
- Mounting pad for mounting actuator.
- Temperature range: 0°F to 140°F (PVC), 0°F to 200°F (CPVC).
- Pressure range: 29 inHg vacuum to 150 PSI.
- NSF14/NSF61 approved.

ELECTRIC ACTUATOR FEATURES

- I4 Series electric actuator.
- Weatherproof enclosure IP65.
- Voltages available: 115 VAC, 24 VAC/VDC.
- Duty cycle: 50%.
- IP65 electrical connectors.
- Space heater.
- Extra (2) SPDT adjustable limit switches.
- Temperature range: 0°F to 140°F.