

VA Series "Valve + Actuator"

Compact, High Cycle-Life On/Off Control Valve



The VA Series combines a pneumatic actuator and valve into one body, eliminating packing glands, actuators and mounting kits. There are no exposed moving parts, eliminating pinch points and increasing operator safety. Since the actuator is part of the valve, costs are greatly reduced when compared to standard actuated valves.

Operating life has been tested to well over 1,000,000 cycles, the balanced design reduces friction and wear. The stroke is linear and parallel to the flow reducing the force to close or open the valve dramatically. The internal waterway design was designed for optimum flow characteristics.

FEATURES

- Integrated pneumatic actuator.
- NAMUR solenoid mounting pad.
- Compact assembly.
- Fast valve actuation.
- High CV (flow coefficient).
- High cycle-life.
- Competitive price.
- Complete accessory equipment.

TYPICAL APPLICATIONS

- Air drying equipment.
- Pollution control equipment.
- Process control applications.
- Laundry equipment.
- Textile dyeing and drying.
- Bottling and dispensing equipment.
- Ink and paint dispensing.
- Industrial compressors.

MATERIALS OF CONSTRUCTION

Seats and Seals:

Viton® (standard), BUNA-N, or EPDM.

Body:

Nickel plated brass.

VA SERIES MODEL NUMBERING

Model Number: X VA X X X X

Size (NPT): _____

037 = 3/8"

050 = 1/2"

075 = 3/4"

100 = 1"

125 = 1-1/4"

150 = 1-1/2"

200 = 2"

Actuator Style: _____

C = Closed

O = Open

D = Double Acting

Seat and Seal: _____

VV = Viton®

BB = BUNA

EE = EPDM

Optional:

Solenoid (see website) _____

Limit Switch: _____

GO = Open

GC = Close

G2 = Open and Close

PRESSURE RANGE

29 inHg vacuum to 150 PSI

TEMPERATURE RANGE

-4°F to 176°F (BUNA-N)

-4°F to 302°F (EPDM, Viton®)

CV FACTORS

Size	CV
3/8"	8
1/2"	10
3/4"	13
1"	17
1-1/4"	28
1-1/2"	57
2"	81

VA Series

Compact, High Cycle-Life On/Off Control Valve
(3/8" to 2" sizes available)

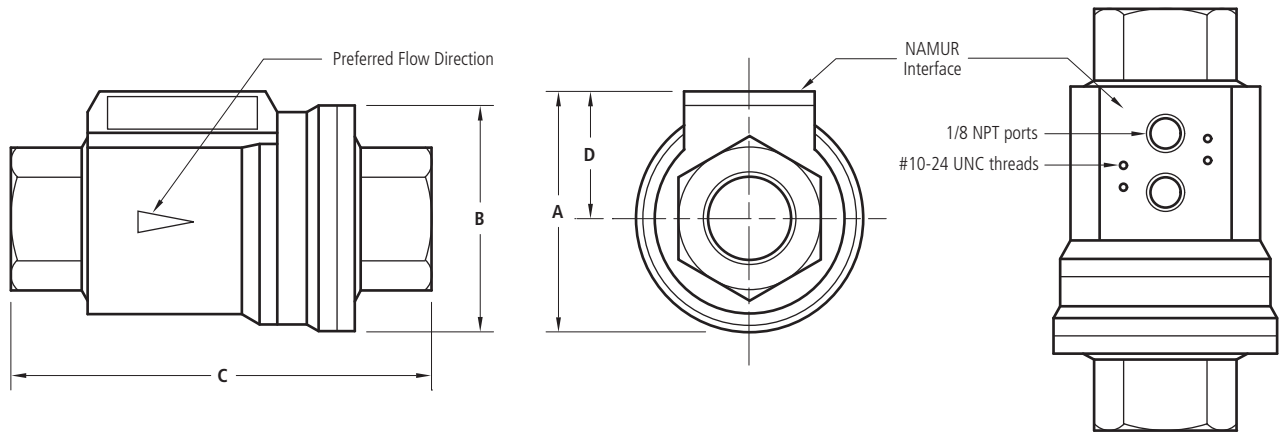

DIMENSIONS, WEIGHTS & SPECIFICATIONS

Size	A	B	C	D	Wt. (lbs.)	Air Consumption	Stroke Time (sec.)			
							Spring Return		Double Acting	
							Spring Stroke	Air Stroke	Air to Open	Air to Close
3/8"	2.11 (54 mm)	1.79 (46 mm)	3.82 (98 mm)	1.21 (31 mm)	1.90	0.73 cu. inches	.02	.01	.01	.01
1/2"	2.34 (60 mm)	2.02 (51.7 mm)	4.37 (112 mm)	1.33 (34 mm)	2.30	1.05 cu. inches	.02	.01	.01	.01
3/4"	2.73 (70 mm)	2.48 (63.5 mm)	5.27 (135 mm)	1.52 (39 mm)	3.70	1.90 cu. inches	.03	.02	.02	.02
1"	2.96 (76 mm)	2.69 (69 mm)	5.58 (143 mm)	1.64 (42 mm)	4.15	2.45 cu. inches	.04	.02	.02	.02
1-1/4"	3.59 (92 mm)	3.35 (86 mm)	6.44 (165 mm)	1.91 (49 mm)	7.50	4.58 cu. inches	.07	.04	.03	.03
1-1/2"	3.98 (102 mm)	3.74 (96 mm)	7.02 (180 mm)	2.11 (54 mm)	8.15	6.70 cu. inches	.11	.06	.06	.06
2"	4.49 (115 mm)	4.25 (109 mm)	8.07 (207 mm)	2.34 (60 mm)	12.75	9.50 cu. inches	.13	.07	.07	.07

VALVE CONFIGURATIONS

- Spring return, NC (normally closed).
- Spring return, NO (normally open).
- Double acting.

ADDITIONAL SPECIFICATIONS

Vacuum Rating:

29 in. (740 mm) Hg (97% vacuum).

Air Pressure Requirement:

40 PSI for double acting, 60 to 125 PSI for spring return.

CROSS SECTIONS, NORMALLY OPEN

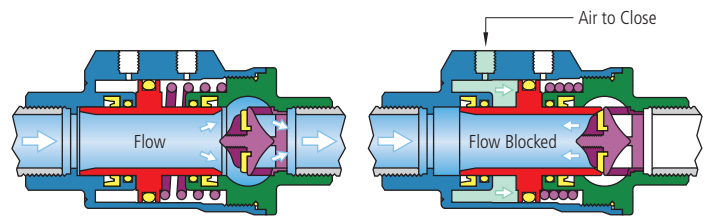

CROSS SECTIONS, NORMALLY CLOSED

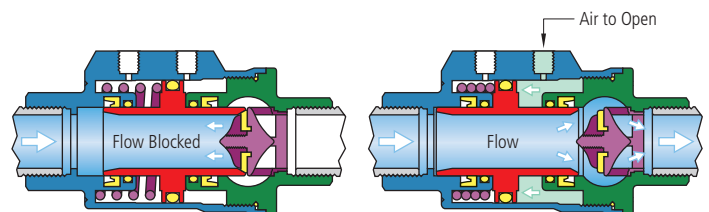

VA Series Limit Switch

Magnetically Driven Limit Switch with LED Indicator

(Installed during valve assembly)

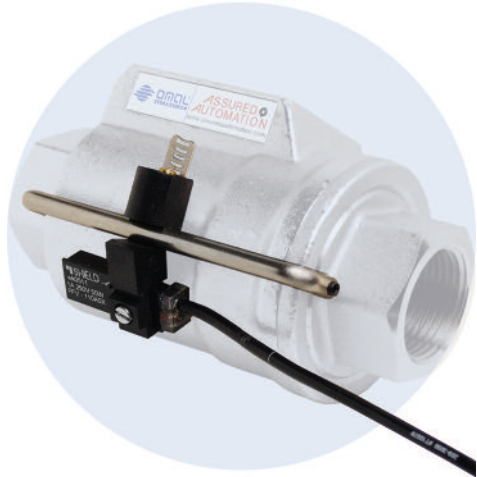

The VA Series valve can be provided with magnetically driven limit switches and an LED indicator. The limit switches are fixed to the outside of the unit. The magnets are situated inside the valve and must be installed during valve assembly, for this reason the switches must be requested at the time of order.

SPECIFICATIONS

Switching Indicator:

LED.

Protection Level:

IP 67.

Nominal Voltage:

3 - 250 VDC (direct current),
3 - 250 VAC (alternating current).

Voltage Drop:

2.5 V.

Maximum Current at 77° F (resistive load):

1 A.

Protection Against Inductive Tension Peaks:

250 VR.

Maximum Applicable Load:

10 W (with suppressor), 10 W (simple).

Life:

10×10^6 .

Repeatability:

0.004".

Operating Time (resistive load):

2 ms.

Release Time (resistive load):

0.1 ms.

Impact Resistance (11 ms):

50 g.

Vibration Resistance:

1000 Hz.

Sensor Type:

1.

Connecting Cable:

10' cable.

MAXIMUM POWER

50 W (direct current),
50 VA (alternating current).

TEMPERATURE RANGE

-22°F to 176°F

DIMENSION

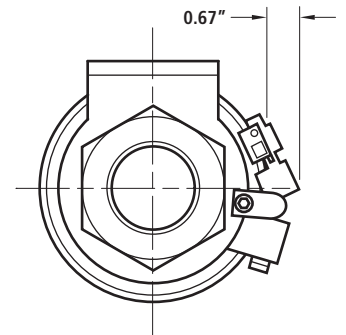

WIRING DIAGRAM

